

SPECIFICATION

HTC-VR, HTC-VVR-RH, HTC-VVR-T, HTC-VVVR, HTC-VR-P, HTC-VVR-RH-P



Wall-mounted CO2 converter with adjustable threshold value and temperature and humidity measurement

2016-02-22

HOTCOLD s.c. 05-120 Legionowo, Reymonta 12/26 tel./fax 22 784 11 47

Introduction.....	3
Device functions.....	3
Device characteristic.....	3
Technical data.....	4
General converter parameters.....	4
CO2 measurement parameters.....	4
Temperature measurement parameters.....	4
Humidity measurement parameters.....	4
Analogue outputs parameters.....	5
Relay output parameters.....	5
Thermocouple parameters (optional).....	5
Installation.....	5
Safety.....	5
Device construction.....	6
Description of terminals.....	6
Device configuration.....	8
LED signalling.....	9
.....	9

Introduction

The subject of this manual is the characteristic of functionality of the CO₂ (carbon dioxide) converter based on the TELAIRE 6613 sensor with 0-10V analogue output and potential-free relay output, equipped depending on the version with the temperature measurement sensor and relative humidity measurement sensor.

CAUTION: Before starting the module, please read the text included in this manual.

Device functions

- **CO₂** measurement
- 0-10 [V] analogue output (proportional to CO₂)
- **temperature** measurement
- 0-10 [V] analogue output (proportional to temperature)
- **relative humidity** measurement
- 0-10 [V] analogue output (proportional to relative humidity)
- potential-free relay output
- configuration of the CO₂ value causing the start-up of converter
- LED signalling of device operation

Device characteristic

The basic function of the CO₂ converter is measurement of the CO₂ content in the air. The device in a wall-mounted version is at the same time the CO₂, temperature and humidity converter. Measured by means of an integrated TELAIRE 6613 sensor CO₂ content, by DS18B20 sensor - temperature value and humidity value by means of Honeywell brand sensor, are then converted and averaged in a microcontroller. The values are presented in an analogue form on the 0-10 [V] voltage outputs. The converter has also been equipped with potential-free relay output, activated after crossing the threshold values of CO₂. The threshold values are set using configuration jumpers – the detailed description can be found in the section **Device configuration**. Optionally, there is also a possibility to measure temperature using sensor type Pt100, Pt1000, NTC (different values). The output resistive signal is proportional to the used sensor.

Due to the significant impact of temperature measurement on the humidity value, the operation of device has been optimized in terms of power consumption and hence the effect of heating of the humidity sensor has been eliminated. The reduction of power consumption was achieved, among others, thanks to switching the processor to the sleep mode between the consecutive measurements and readings.

Technical data

General converter parameters

Power	
- DC voltage	DC 24V (20...30V)
- AC voltage	AC 24V (20...27,6V)
Current consumption	
- minimal ¹⁾	38,0 mA
- typical ²⁾	77,0 mA
- maximum ³⁾	90,0 mA
LED signalling	Description in the section: "LED signalling"
Installation connector	screw 5.00mm increments ($\leq 2,5\text{mm}^2$)
Dimensions	120 x 80 x 25 (L x H x W)
Weight	150 g
Installation ⁴⁾	-
Working environment	Dust-free, air, neutral gases
Working temperature	0°C ÷ 50°C

1) Minimum momentary power consumption in the conditions: 24V DC, each voltage output loaded with 1k resistance, converter on;

1) Medium power consumption of the device under conditions as in section 1);

2) Maximum momentary power consumption of the device under conditions as in section 1);

3) The installation of the device should be carried out by qualified personnel;

CO2 measurement parameters

Type of sensor	TELAIRE 6613
Measurement range	0 ÷ 2000 ppm
Accuracy:	
- within the range of 400 ÷ 1250 ppm	± 3 %
- within the range of 1250 ÷ 2000 ppm	± 5 % ± 30 ppm
Sampling frequency	2 Hz
Response time ¹⁾	< 2 min

1) The specified response time is equal to one time constant corresponding to 90% of set value;

Temperature measurement parameters

Type of sensor	DS18B20
Measurement range	0°C ÷ 50°C
Resolution	12 bit (0,05 °C)
Accuracy	±0,5 °C
Sampling frequency	0,5 Hz
Response time ¹⁾	750ms

1) The condition for achieving the specified response times is the airflow > 1m/s; the specified response time is equal to one time constant corresponding to 63% of set value;

Humidity measurement parameters

Type of sensor	HIH6031
Measurement range	0 ÷ 100 %RH
Resolution	12 bit (0,05 %RH)
Accuracy for T=25°C	
- within the range of 20 ÷ 80 %RH	±3 %RH
- within the remaining range	±(3 ÷ 5) %RH
Hysteresis	±1 %RH
Sampling frequency	0,5 Hz
Response time ⁵⁾	8 s

1) The condition for achieving the specified response times is the airflow > 1m/s; the specified response time is equal to one time constant corresponding to 63% of set value;

Analogue outputs parameters

Type of output	voltage
Output range	0-10 V
Resolution	12 bit (5 mV)
Load	$R_L > 1 \text{ k}\Omega$
Refresh rate	
- CO2 (carbon dioxide) output	2 Hz
- T1 output (temperature)	0,5 Hz
- RH output (relative humidity)	0,5 Hz

Relay output parameters

Type of output	NO ¹⁾
Nominal / max. AC contact voltage	125 V / 250 V
Minimal contact voltage	10 mV
Nominal load current	
- in AC1 category	0,5 A / 125 V AC
- in DC1 category	2 A / 30 V DC
Minimal contact current	0,01 mA
Permanent contact ampacity	2 A
Maximum switching capacity in AC1 category	62,5 VA
Contact resistance	$\leq 50 \text{ m}\Omega$
Response/return time	3 ms / 3ms
Electrical endurance	
- in AC1 category (1200 cycles/h)	10^5 (0,5A, 125 V AC)
- in DC1 category (1200 cycles /h)	2×10^5 (1A, 30 V DC)
Mechanical strength (10800 cycles /h)	10^8

1) Output normally open;

Thermocouple parameters (optional)

Type of sensor	e.g. Pt100, Pt1000, NTC 1,8K, 5.02K, 10K, 20K
Measurement range	-40 °C ÷ 80°C

Installation

Safety

- The installation of the device should be carried out by qualified personnel!
- All connections must be made in accordance with wiring diagrams shown in this specification!
- Before starting the device all electrical connections must be checked!

Device construction

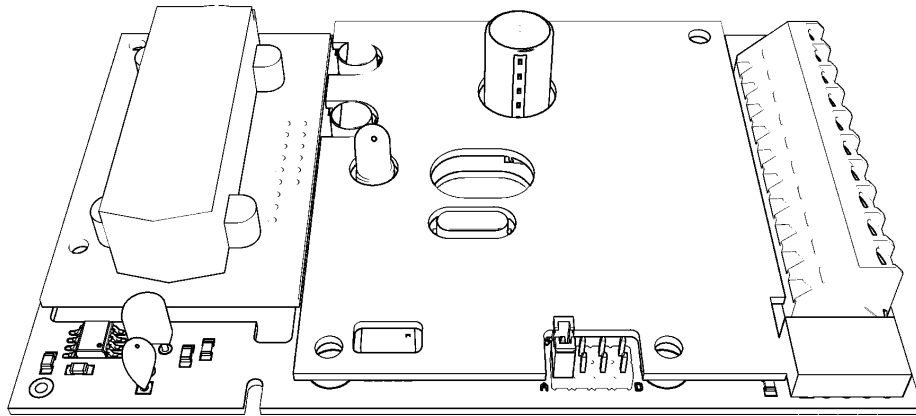

Figure 1. View of the printed circuit board of the **wall-mounted** version of the converter.

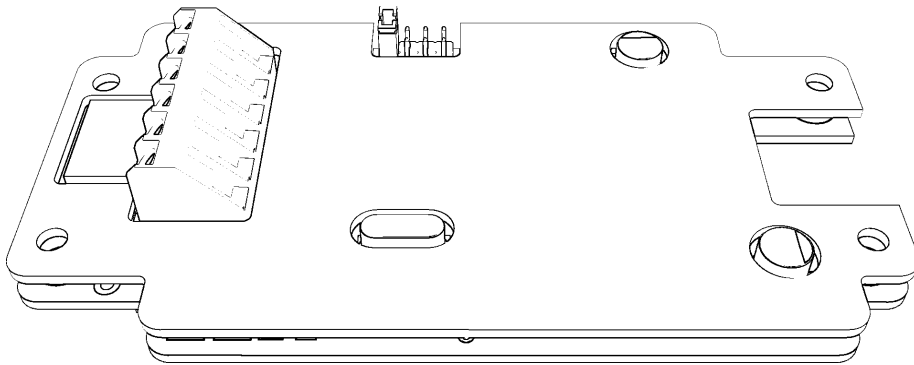

Figure 2. View of the printed circuit board of the **duct** version of the converter.

Description of terminals

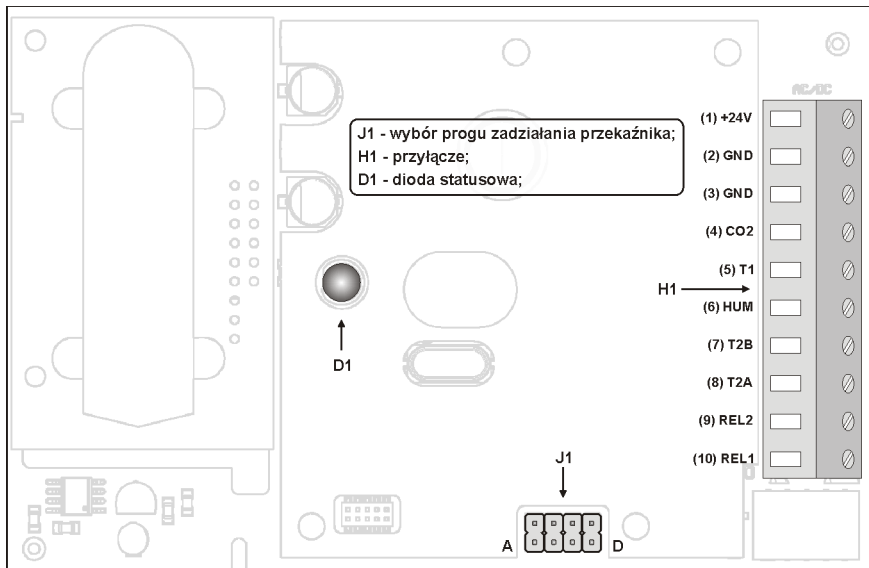

Figure 3. Description of terminals of the CO2 converter.

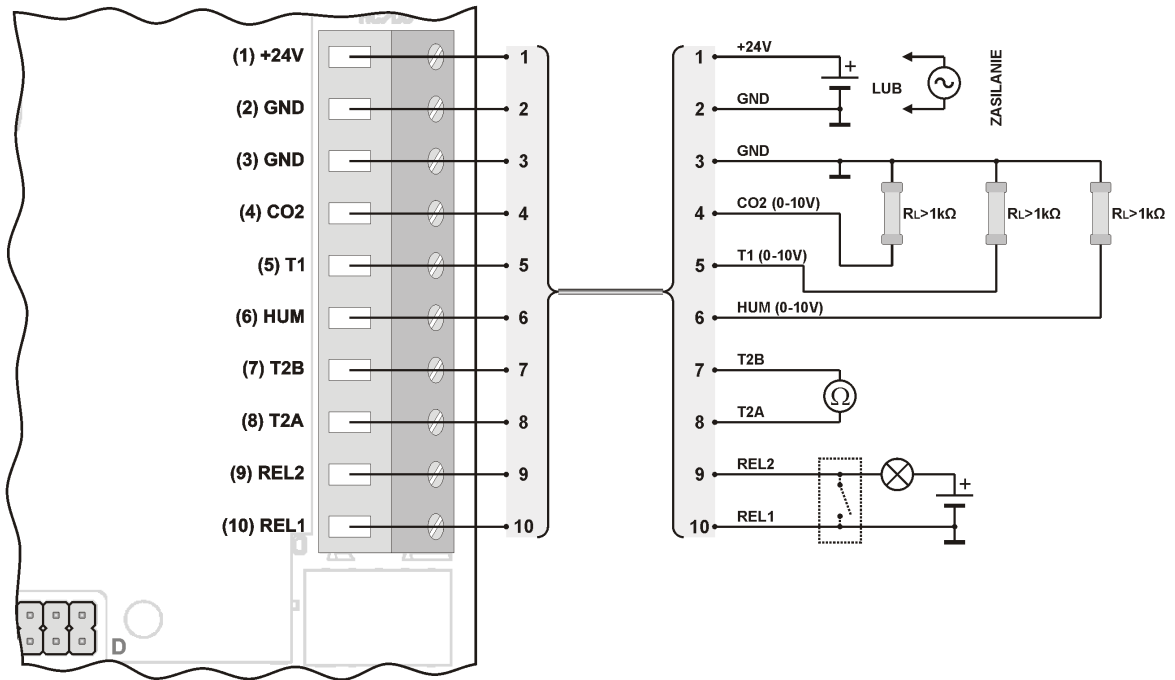

Figure 4. Wiring diagram of the CO2 converter.

Device configuration

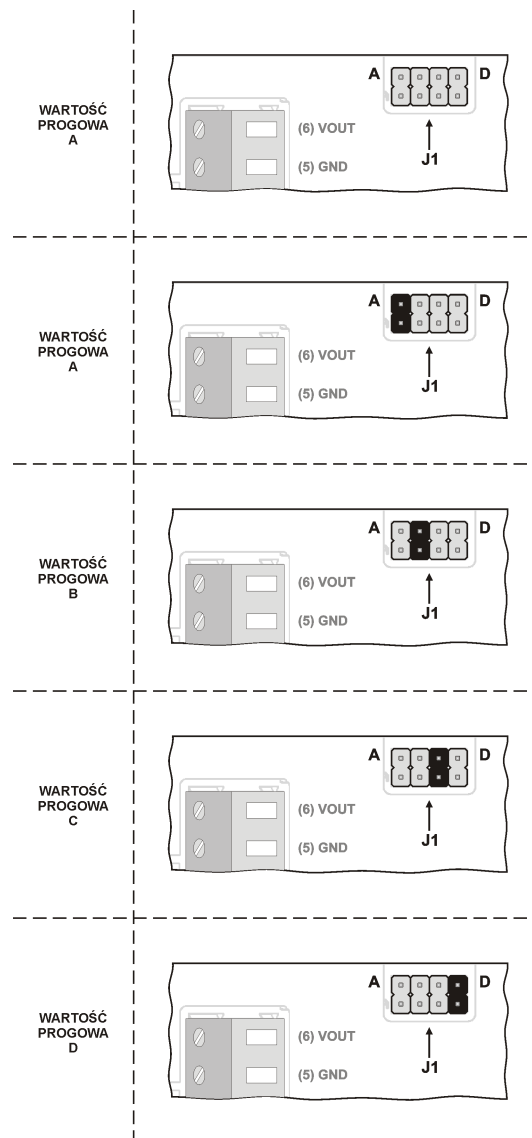

Figure 5. Configuration of threshold value switching the relay output of the CO2 converter.

Table of threshold values switching the relay output:

Jumper position	Carbon dioxide values *
A	800 ppm
B	1200 ppm
C	1600 ppm
D	Factory setting

(*) Hysteresis of the switching of relay output equals ± 50 ppm.

LED signalling

Table of statuses signalled by status LED:

Status	Description	Diode colour	Behaviour
1	Warming of CO2 module	green	blinking (250ms / 250ms ^{**})
2	0 – 800 [ppm] *	green	continuous light
3	800 – 1200 [ppm] *	yellow	continuous light
4	1200 – 2000 [ppm] *	red	continuous light
5	> 2000 [ppm]	red	blinking (250ms / 250ms ^{**})
6	no CO2 sensor or other error	red	blinking (100ms / 600ms ^{**})

(*) Hysteresis of the switching of the status of diode light equals ± 50 ppm.

(**) Blinking (XXX ms / YYY ms) means XXX – time of switching on, YYY – time of switching off

5. Available models

MODEL	Description
HTC-VR	Measurement of CO2/0...10 V + relay threshold
HTC-VVR-RH	Measurement of CO2/0...10 V + relay threshold: measurement of RH/0...10 V
HTC-VVR-T	Measurement of CO2/0...10 V + relay threshold: measurement of temp./0...10 V
HTC-VVVR	Measurement of CO2/0...10 V + relay threshold: measurement of RH/0...10 V; measurement of temp./0...10 V
HTC-VR-P	Measurement of CO2/0...10 V + relay threshold: measurement of temp./ RTD sensor
HTC-VVR-RH-P	Measurement of CO2/0...10 V + relay threshold; measurement of RH/0...10 V; measurement of temp./ RTD sensor

